

Directional valve 2-way/2-position

$Q_{\max} = 36 \text{ gpm}$, $p_{\max} = 5000 \text{ psi}$

switching solenoid with emergency override, pilot operated, poppet type

Type series: WRA22O_DA-10...



- Screw-in cartridge valve
- For cavity DD
- All external parts with zinc-nickel coating according to DIN EN ISO 19598
- Installation in threaded port body type DD-12 / DDY-12
- The slip-on coil can be rotated, and it can be replaced without opening the hydraulic envelope
- High pressure wet-armature solenoids
- Various plug-connector systems and voltages are available
- Seat tight shut-off
- High flow rates
- With manual override
- Also available as stack valve

Description

The 2-way/2-position solenoid-operated directional seat valves, series WRA22_D..., are size 10, two stage, screw-in valves with an M24x1,5 mounting thread. The main and pilot stages are both designed on the poppet/seat principle, therefore virtually leak-free. The straightforward design delivers a good price/performance ratio and outstanding head loss/ flow ratings. All external parts of the screw-in valves are zinc-nickel plated, and are thus suitable for use in the harshest

operating environments. The slip-on coils can be replaced without opening the hydraulic envelope and can be positioned at any angle through 360°. These valves are primarily used as pilot valves in certain mobile and industrial applications where leak-tight shut-off functions are crucially important. Examples are where loads, tensions, or clamping forces must be held without leakage. For self-assembly, please refer to the section related data sheets.

Symbol

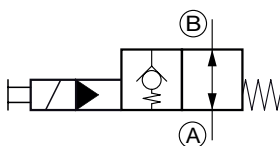

Technical Data

General Characteristics	Description, value, unit
Function group	Directional valve
Function	2-way/2-position
Design	Screw-in cartridge valve
Controls	switching solenoid with emergency override
Characteristic	pilot operated, poppet type
Construction size	nominal size 10
Thread size	M24×1,5
Mounting attitude	unrestricted
Weight	1.10 lb
Cavity acc. factory standard	For cavity DD
Tightening torque steel	48 ft·lb
Tightening torque aluminium	37 ft·lb
Tightening torque tolerance	± 10 %
Minimum ambient temperature	- 13 °F
Maximum ambient temperature	+ 122 °F
Surface protection	All external parts with zinc-nickel coating according to DIN EN ISO 19598
Available seal types	several seal types available, see ordering code
Seal kit order number	NBR: DS-276-N / FKM: DS-276-V

Hydraulic Characteristics	Description, value, unit
Maximum operating pressure	5000 psi
Maximum flow rate	36 gpm
Flow direction	see symbol
Hydraulic fluid	HL and HLP mineral oil according to DIN 51 524; other fluids on request!
Minimum fluid temperature	- 13 °F
Maximum fluid temperature	+ 176 °F
Viscosity range	10 ... 500 mm ² /s (cSt)
Recommended viscosity range	15 ... 250 mm ² /s (cSt)
Minimum fluid cleanliness (cleanliness class according to ISO 4406:1999)	class 20/18/15

Electric Characteristics	Description, value, unit
Actuator type	solenoid coil
Solenoid coils type	D36
Supply voltage DC	12/24 V DC
Supply voltage AC	115/230 V AC (50 ... 60 Hz)
Supply voltage tolerance	± 10 %
Maximum permissible power consumption	Version "E": V DC = 17 W / V AC = 17 W Version "N": V DC = 27 W / V AC = 25 W
Switching time	Version "E": 66...132 ms (energized) / 16...66 ms (de-energized) Version "N": 54...142 ms (energized) / 18...60 ms (de-energized)

Electric Characteristics	Description, value, unit
Relative duty cycle	100 %
Electrical connection coil	several connection types available, see ordering code
Protection class solenoid coil to ISO 20 653 / EN 60 529	several classes of protection available, see ordering code (with appropriate mating connector and proper fitting and sealing)



NOTE!

The switching time can be strongly dependent on flow rate, pressure, oil viscosity and the dwell time under pressure. In practice, the switching time may therefore deviate from the specified value range.

Performance graphs

measured with oil viscosity 33.0 mm²/s (cSt), coil at steady-state temperature and 10 % undervoltage

$\Delta p = f(Q)$ Pressure drop-flow rate characteristic

Δp [bar (psi)]

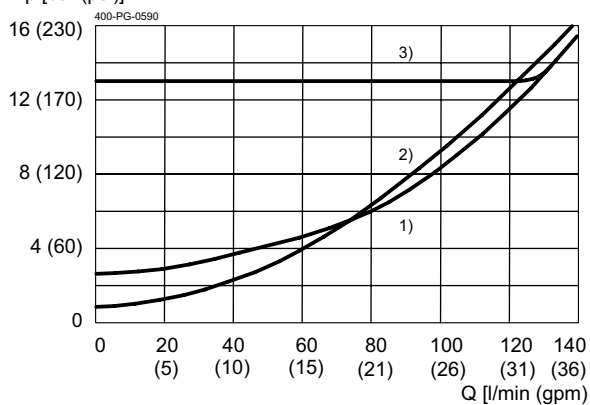

- 1) = B → A, de-energized
- 2) = A → B, de-energized
- 3) = B → A, energized

Version "E" - 17 W

$\Delta p = f(Q)$ Pressure drop-flow rate characteristic

Δp [bar (psi)]

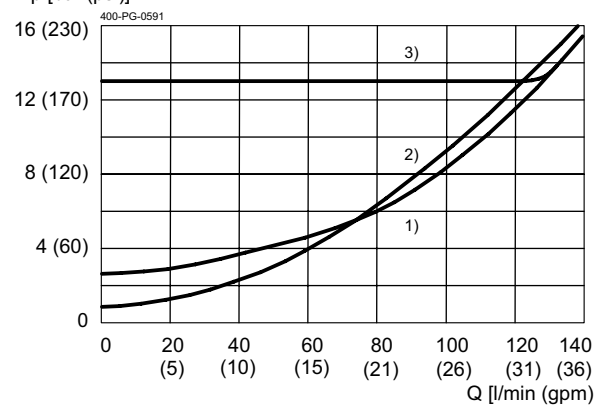

- 1) = B → A, de-energized
- 2) = A → B, de-energized
- 3) = B → A, energized

Version "N" - 27/25 W

Dimensions and sectional view

Beispiel für die Masseinheit:
Example for the dimensional units:
0.79 = 0.79 mm millimeter
(.031) = 0.031" inch

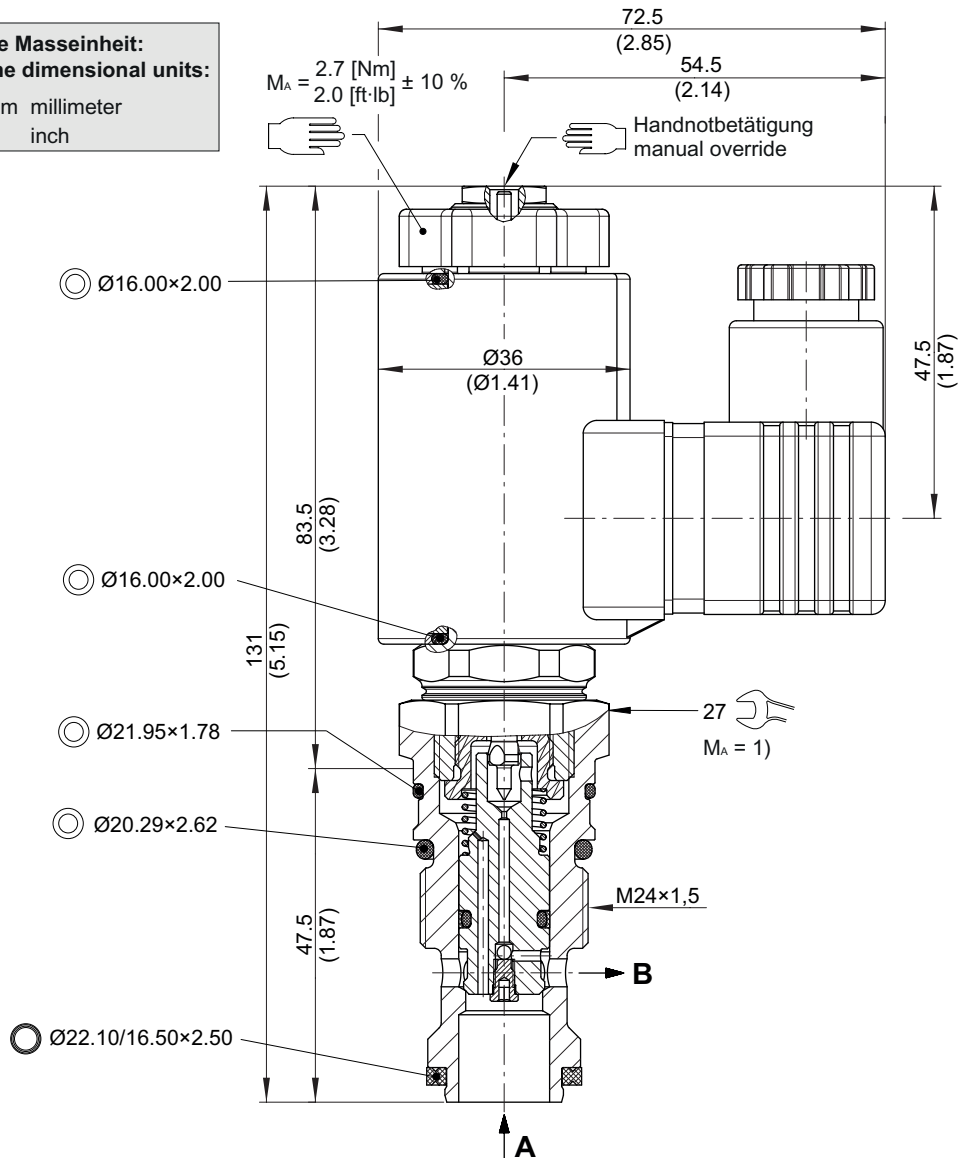

Installation information



NOTE!

1) When fitting the screw-in cartridge valve, use the specified tightening torque. The value can be found in the chapter "technical data".



NOTE!

The seals are not available individually. The seal kit order number can be found in the chapter "Technical data".



ATTENTION!

Only qualified personnel with mechanical skills may carry out any maintenance work. Generally, the only work that should ever be undertaken is to check, and possibly replace, the seals. When changing seals, oil or grease the new seals thoroughly before fitting them.

Ordering code

Ex.

W	R	A	220	E	D	A	-	10	-	3	-	24	D	-	-
---	---	---	-----	---	---	---	---	----	---	---	---	----	---	---	---

- W = directional valve
- R = check valve function, pilot operated
- A = blocking direction A to B
- 220 = 2-way/2-position, normally open
- E = electrically operated, V DC = 17 W / V AC = 17 W (standard)
- N = electrically operated, V DC = 27 W / V AC = 25 W
- D = cavity type DD
- A ... Q = standard model according to valid data sheet (standard)
- Z ... R = special model after consultation
- 10 = nominal size 10
- (blank) = NBR (nitril-butadien-rubber / BUNA) seals (standard)
- V = FKM (fluorocarbon rubber / VITON) seals
(special seals - please consult BUCHER)
- 1 ... 9 = technical design no. (omit when ordering)
- ... = voltage e.g. 24 (24 V)
- D = current DC
- A = current AC
- (blank) = DIN EN 175301-803 connection, 3-pole 2 P+E with mating plug, IP 65 (standard)
- M100 = DIN EN 175301-803 connection, 3-pole 2 P+E
- C = Kostal plug connection (IP 65)
- JT = Junior Timer radial plug connection (with protection diode, IP 65)
- IT = Junior Timer axial plug connection (with protection diode, IP 65)
- D = Deutsch plug connection DT04-2P (IP 67/69K)
- DT = Deutsch plug connection DT04-2P (with protection diode, IP 67/69K)
- S = AMP Superseal 1.5 (IP 67) / Metri-Pack 150 (IP 65) plug connection
- F = flying leads (500 mm)

} mating plug not supplied

Related data sheets

Reference	Description
400-P-040011	Forming tools
400-P-060121	Cavity DD
400-P-740111	Threaded port body DD-12
400-P-740112	Threaded port body DDY-12
400-P-120110	Solenoid coil D36

info.ch@bucherhydraulics.com

www.bucherhydraulics.com

© 2021 by Bucher Hydraulics AG Frutigen, 3714 Frutigen, Switzerland

All rights reserved.

Data is provided for the purpose of product description only, and must not be construed as warranted characteristics in the legal sense. The information does not relieve users from the duty of conducting their own evaluations and tests. Because the products are subject to continual improvement, we reserve the right to amend the product specifications contained in this catalogue.